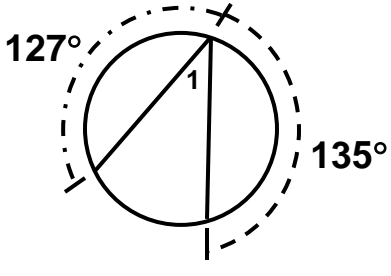
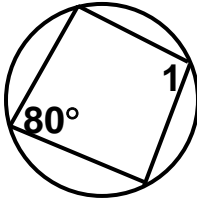
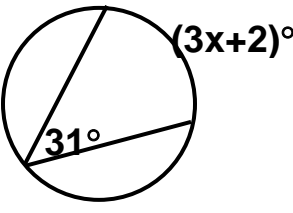
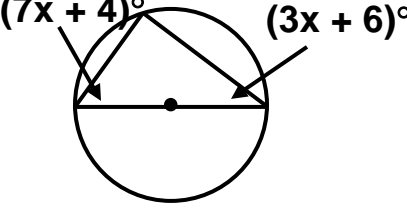

NAME _____ DATE _____ PER. _____

REVIEW #14: MORE CIRCLES

PART 1: CIRCLES & ANGLES

Find the indicated measure for each of the following.

<p>1. $m\angle 1 =$ _____</p>	<p>Find the $m\angle 1$.</p>	
<p>2. $m\angle 1 =$ _____</p>	<p>Find the $m\angle 1$.</p>	
<p>3. $x =$ _____</p>	<p>Find the value of 'x'.</p>	
<p>4. $x =$ _____</p>	<p>Find the value of 'x'.</p>	

Find the $m\angle 1$ for each of the following.

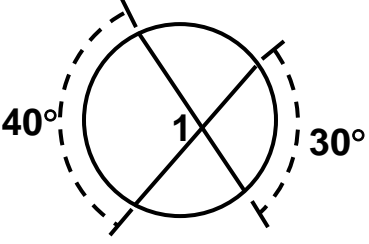
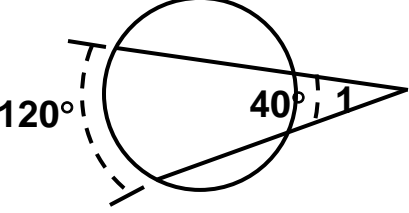
<p>5. _____</p>	
<p>6. _____</p>	

<p>7. _____</p>	
<p>8. _____</p>	

Find the indicated measure.

<p>9. $x =$ _____</p>	
<p>10. $x =$ _____</p>	
<p>11. _____</p>	<p>$m\angle 1 = (2x + 5)^\circ$ and $m\angle 2 = (6x - 3)^\circ$. Find $m \widehat{ST}$.</p>

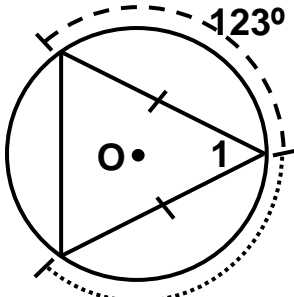
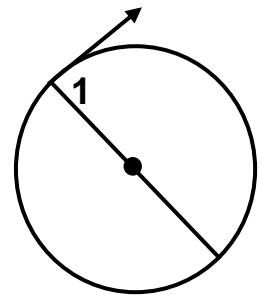
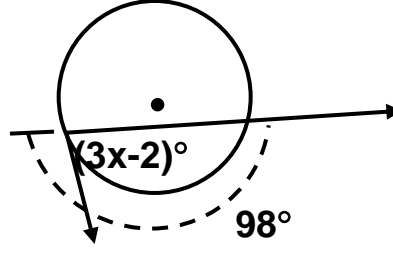
<p>12. $m\angle 1 =$ _____</p>	
<p>13. $m\angle 1 =$ _____</p>	
<p>14. $x =$ _____</p>	

\overleftrightarrow{AB} is tangent to circle O. \overline{AF} is a diameter. $m\widehat{AG} = 100^\circ$, $m\widehat{CE} = 30^\circ$ and $m\widehat{EF} = 25^\circ$. Find each of the following.

15. $m\angle 1 =$ _____
16. $m\angle 2 =$ _____
17. $m\angle 3 =$ _____
18. $m\angle 4 =$ _____
19. $m\angle 5 =$ _____
20. $m\angle 6 =$ _____
21. $m\angle 7 =$ _____

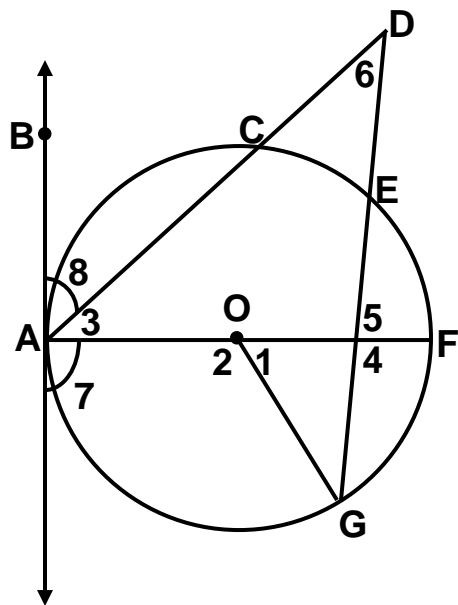

22. $m\angle 8 =$ _____

PART 2: SPECIAL SEGMENTS IN CIRCLES

Find the indicated value for each of the following.

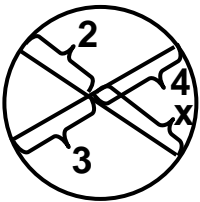
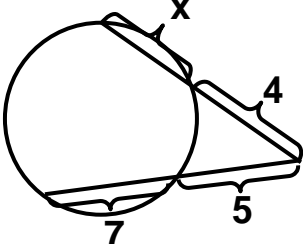
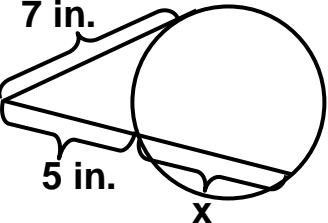
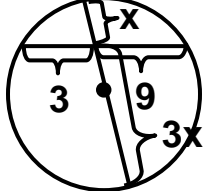
<p>23. $x =$ _____</p>	
<p>24. $x =$ _____</p>	
<p>25. $x =$ _____</p>	
<p>26. $r =$ _____</p>	

PART 3: CIRCLES ON THE COORDINATE PLANE

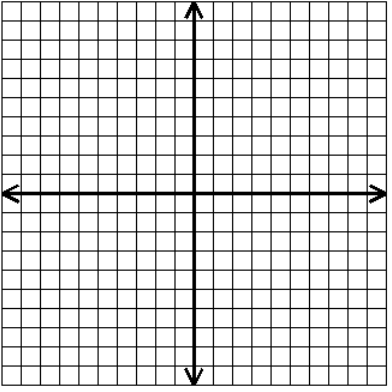
<p>27. $r =$ _____</p> <p>center: _____</p>	<p>Graph $(x - 2)^2 + (y + 1)^2 = 4$</p> 
--	---

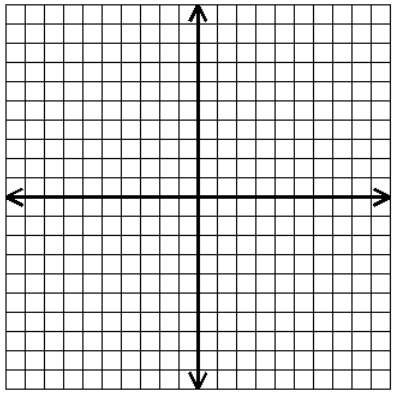
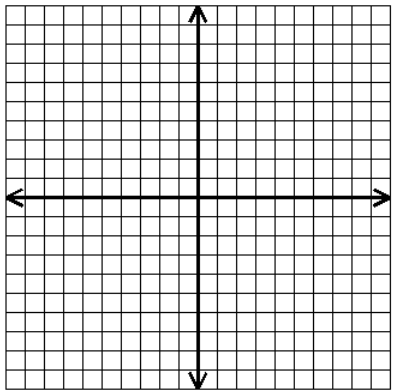
<p>28. $r =$ _____</p> <p>center: _____</p>	<p>Graph $(x + 2)^2 + (y - 2)^2 = 16$</p>	
<p>29. $r =$ _____</p> <p>center: _____</p>	<p>Graph $(x + 3)^2 + (y - 6)^2 = 24$</p>	

Write the equation for the following circles in standard form.

<p>30. _____</p>	<p>Center at $(1, -1)$ and radius of 4</p>
<p>31. _____</p>	<p>Center at $(2, -3)$ and passes through $(-1, 1)$</p>
<p>32. _____</p>	<p>Center at $(-6, 3)$ and radius of $4\sqrt{2}$.</p>
<p>33. _____</p>	<p>Center at $(-2, 0)$ and passes through $(-2, -2)$</p>

34. _____	$x^2 + y^2 - 10x + 2y + 16 = 0$
35. _____	$x^2 + y^2 - 2x - 4y - 4 = 0$
36. _____	$4x^2 + 4y^2 - 16x + 24y + 16 = 0$

Look over:

- All definitions for the parts of a circle.
- Past homework assignments.